

Thermal Considerations for Driving LED Strings with CCRs

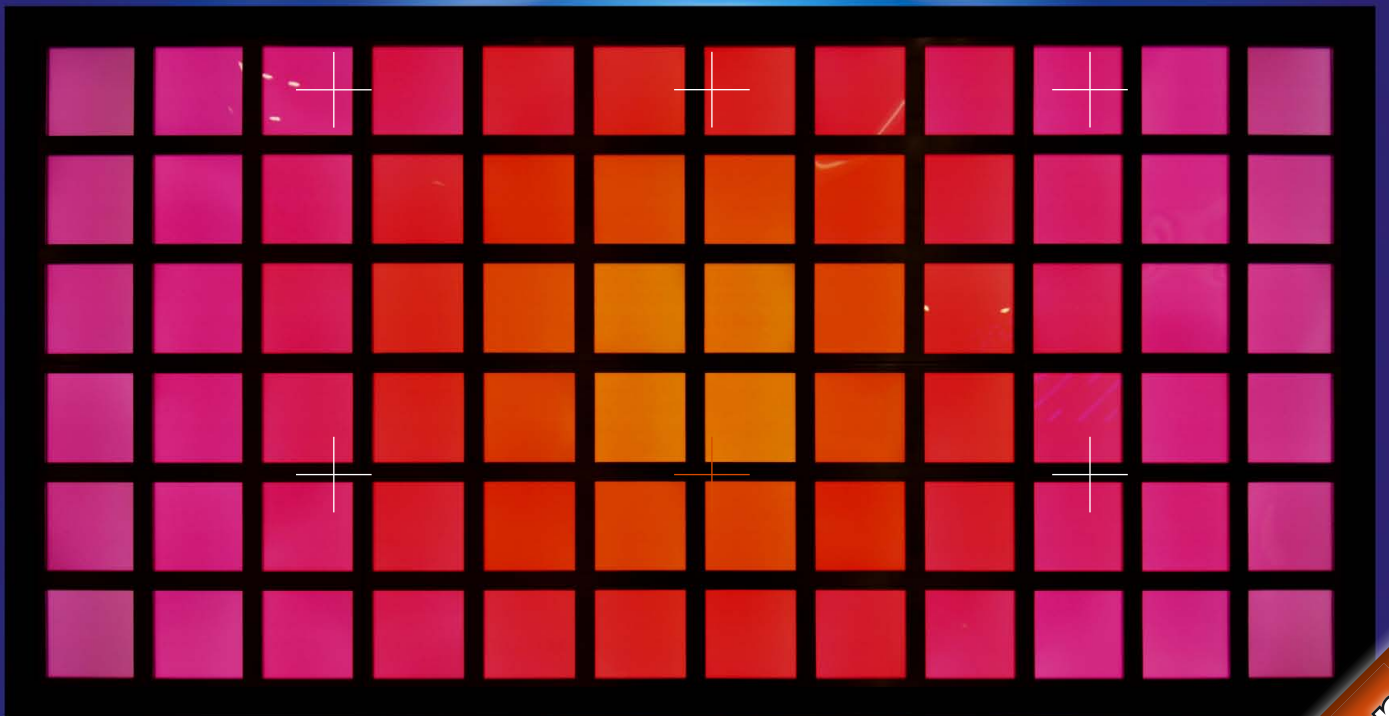

Author's Edition

FOR MORE LED ARTICLES
join our list of subscribers at
www.led-professional.com
and receive your
LED professional Review

FREE EDITION

Thermal Considerations for Driving LED Strings with CCRs

Constant Current Regulators (CCRs) controlling current in solid-state lighting applications must be considered within the overall system thermal design to ensure reliability and consistent performance. Steve Sheard, Strategic Programs Manager for Standard Products at ON Semiconductor discusses in detail why this is so important.

Low-cost and simplified control techniques are needed to encourage adoption of LED technology in applications such as domestic replacement bulbs or automotive interior and exterior lamps. Supplying the LED – or series-connected string in a multiple-LED system - with a constant forward current is the preferred means of ensuring consistent luminosity and preventing damage to the LEDs caused by over driving.

A resistor in series with the LED string is the simplest means of regulating the current, but there are a number of shortcomings. The resistor has relatively high power dissipation, which reduces overall efficiency and generates significant heat. In addition, the resistor provides no protection against voltage variations, which can affect the light generated. Very high voltage transients are capable of damaging the LEDs.

A Constant-Current Regulator (CCR) based on a self-biasing transistor can provide a cost-effective and straightforward means of supplying a regulated current to the LED string, avoiding many of the drawbacks of a pure series resistor. The CCR also has a negative current-versus-temperature characteristic as ambient temperature increases, which provides protection against thermal runaway. It is a popular solution in applications where the applied voltage can vary over a wide range, such as domestic lamps and automotive lighting.

A number of CCR variants are available, such as two-terminal devices that regulate the LED current to a preset value or three-terminal devices that allow the current to be programmed using one external resistor. Built-in surge suppression provides inherent over-voltage protection for the LEDs.

In addition to its simplicity, the CCR is also a versatile solution since it can be used as a high-side or low-side regulator; automotive applications often require a high-side device as the LED low-side connection is typically grounded directly to the vehicle body. Figure 1 illustrates a generic CCR-controlled LED lighting circuit.

Thermal Management in LED-lighting Design

For good CCR implementations, close attention to the thermal management is essential throughout the design. The

designer must consider thermal effects not only on the LEDs and associated passive components such as electrolytic capacitors but also on the CCR itself since the regulator conducts the full LED driving current; the power dissipated within the device cannot be ignored.

Although high-power LEDs operate significantly more efficiently as light sources than incandescent lamps, a significant proportion of energy supplied is converted into heat. Inadequate thermal design will allow this heat to produce a temperature rise in the LED, which can have a number of unwanted effects. The luminosity of an LED emitter decreases as the semiconductor junction temperature increases. The LED can be destroyed if the junction temperature exceeds the manufacturer's stated maximum; usually 150°C.

Changes in temperature can also alter the wavelength of light emitted by coloured LEDs, or the Corrected Colour Temperature (CCT) of white LEDs, producing noticeable changes in lighting. Moreover, as with any other semiconductor device, reliability is impaired by prolonged operation at elevated temperatures. In LEDs, this can be measured as a reduction in light output over time.

The change in light output with time, in relation to initially measured output, is quantified in terms of lumen maintenance. This is used to define the useful lifetime of an LED lamp, and

Figure 1:
Generic CCR-controlled LED lighting circuit

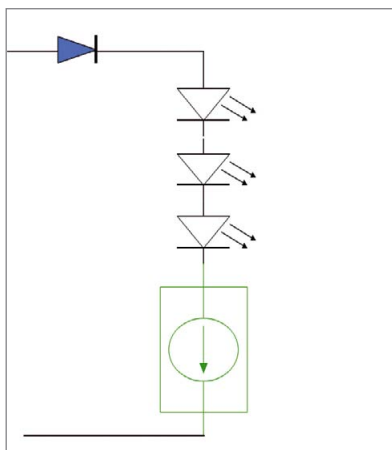

compares with the time to failure of a conventional incandescent lamp which tends to dim gradually before failing completely. Since LEDs generally do not fail catastrophically, end of life can be determined as the point at which luminosity has fallen below an acceptable level. For most applications this is accepted to be around 70% of the initial light output, or 80% in applications where a small reduction may be highly noticeable.

LED manufacturers may publish graphs relating lumen output, temperature and drive current for a given emitter type, enabling designers to predict the lifetime after which the light output will have fallen below 70% of its initial value (L70) or below 80% (L80). These graphs enable lighting designers to determine the optimum current and operating temperature to guarantee the required light output up to the target lifetime. This information can then be used to determine the

drive characteristic, total number of LEDs required and thermal design to meet system-level requirements including size and cost.

Designers must consider all of these effects when determining the number and type of LEDs to be used, the drive conditions and the heat sinking provided. Some LED manufacturers publish design guides that include recommendations such as PCB substrate type or metallisation beneath and around the device. The thermal design of the PCB has an important role in helping to extract heat from the LED junction, through the package and into the ambient, to maintain a stable operating temperature under given driving conditions.

The heat generated by the LED array is a major factor determining the temperature of the lamp assembly as a whole, and can strongly influence the surrounding ambient temperature if the

lamp is to be used in a confined space. Hence, in addition to calculating the lifetime of the LEDs, designers must also ensure the surrounding electronic components are capable of operating for the intended lifetime of the lamp. Factors to consider include thermal effects on electrolytic capacitors in the rectifying or voltage regulation circuitry. Operation at high temperatures results in drying of liquid electrolyte, producing a loss of capacitance. Hence capacitors may need to be derated according to the datasheet, to guarantee the minimum required capacitance over temperature and time.

Thermal Management of CCR Controller

In a CCR-controlled system the full LED drive current flowing in the regulator can produce significant self heating. Hence the thermal performance of the system around the regulator requires careful consideration. A key parameter is the quantity of heatsinking provided, such as the area and thickness of copper on the PCB, or whether to specify a thermally enhanced substrate. The graphs shown in figure 2 demonstrate how power dissipation falls as the ambient temperature increases. The traces show performance with a variety of substrate characteristics. These graphs are published in CCR datasheets, and can be used to guide device selection and PCB design.

For a series circuit, the maximum power dissipated by the CCR is determined by:

$$P_D = (V_{\text{source}} - (V_{\text{LEDS}} + V_{\text{RPD}})) \times I_{\text{reg}}$$

where V_{RPD} is the voltage across the reverse-battery protection diode, where included.

Worst-case values should be used when calculating P_D for thermal design purposes. That is, the highest V_{source} , lowest LED V_F , and highest target I_{reg} . Note that the power dissipation can be reduced for a pulse-width modulation controlled circuit.

Figure 2: Power dissipation versus ambient temperature for CCR in SOD123 package, for a variety of copper heat-spreader specifications

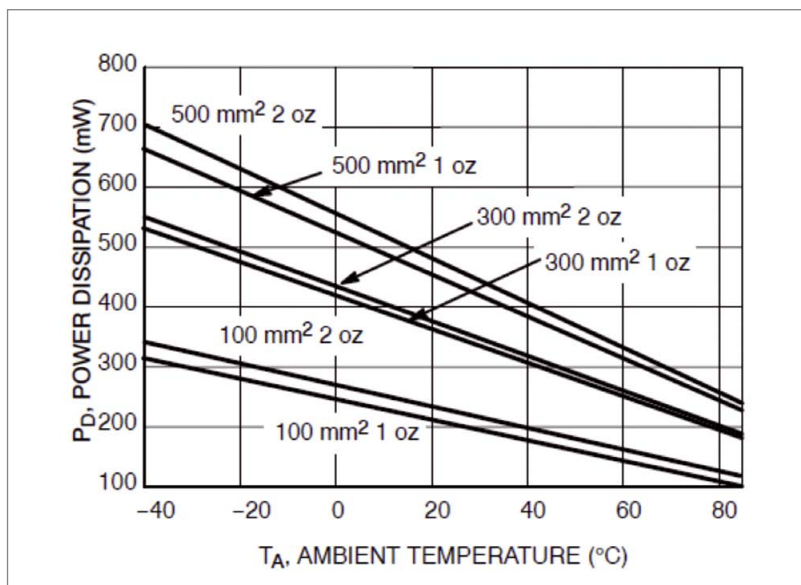

Figure 3: CCR in high-side circuit of automotive LED-lighting unit

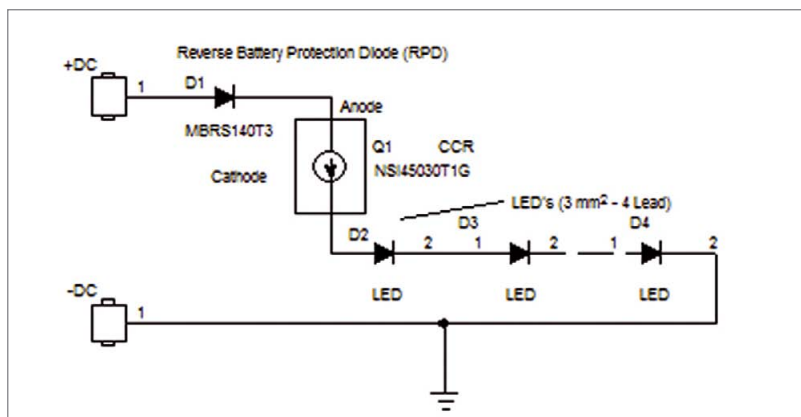
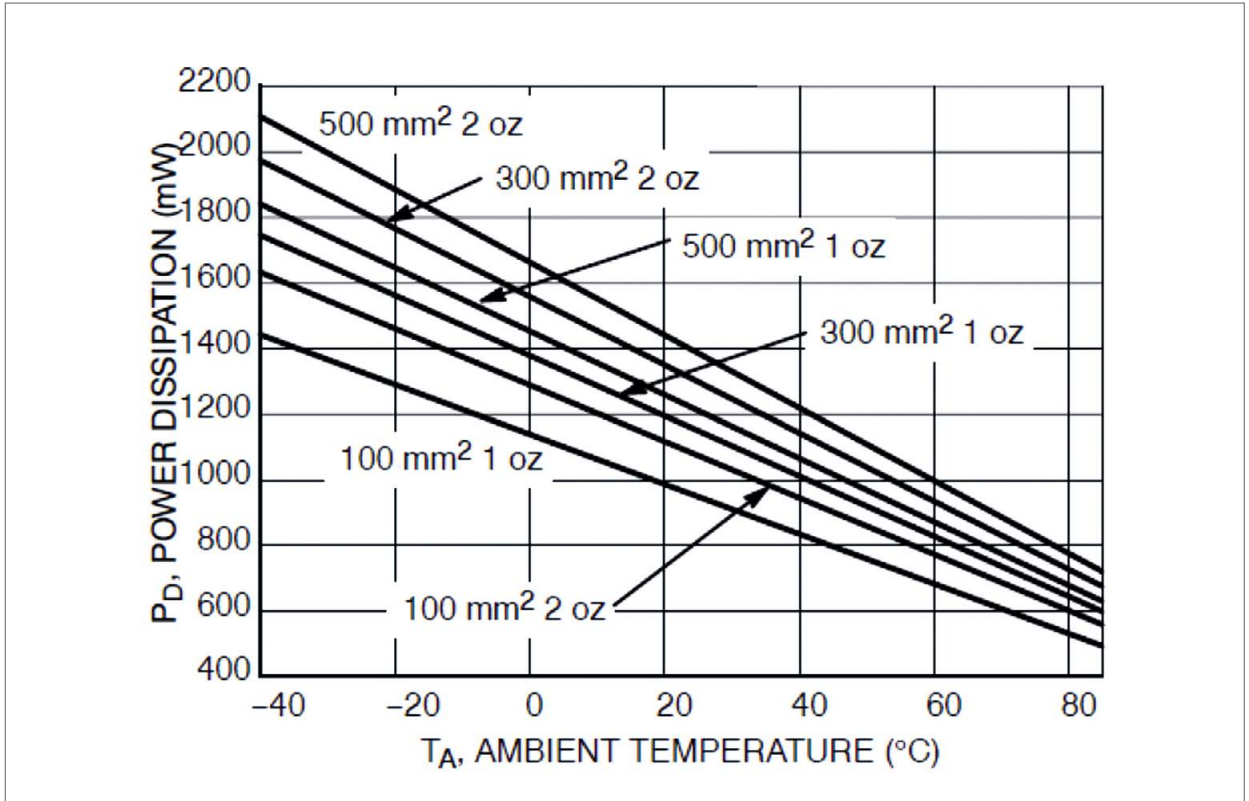

Figure 4:
Power dissipation versus ambient temperature for CCR in SOT-223 package



Consider the example of an automotive light unit comprising three red LEDs in series, as shown in figure 3. Assuming a maximum supply voltage of 16 V from the vehicle regulator, and worst-case forward voltage V_F of $2.0 V_{dc}$ for each LED, $0.2 V_{dc}$ forward voltage of the Schottky diode, the maximum power dissipated in the CCR can be calculated:

$$P_D = (16 V_{dc} - (3 \times 2.0 V_{dc}) + 0.2 V_{dc}) \times 30 \text{ mA} = 294 \text{ mW}$$

If designing for an ambient temperature of 85°C , figure 2 shows that the CCR in a SOD-123 package requires the substrate to have more than 500 mm^2 of copper. In contrast, figure 4 indicates that the required PD can be met using 100 mm^2 of 1oz copper using an equivalent CCR in a SOT-223 package. The SOT-223 has lower thermal resistance ($R_{\theta ja}$) than the SOD-123. In practice, the size constraints of the application may in fact allow for a larger surface area. Figure 3 shows that a SOT-223 CCR mounted on 300 mm^2 of 1oz copper is capable of dissipating 598 mW, thereby satisfying the worst-case requirement and providing some safety margin.

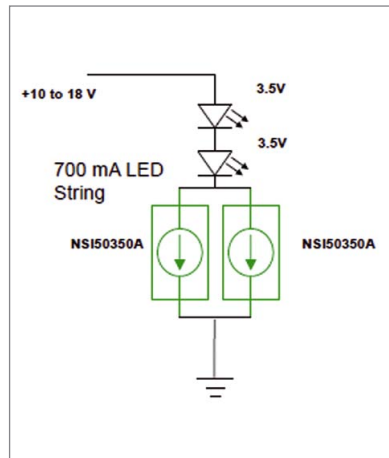

Figure 5: Two CCRs can be connected in parallel for higher current applications

For applications requiring extremely high brightness, such as automotive exterior lighting or commercial signage, devices such as the NSI50350A in the DPAK power package are able to carry load current of up to 350 mA. In addition, two CCRs can be connected in parallel to allow further increases in current-handling capability. By splitting the total power between two CCRs, the thermal effect can be spread over a larger area and less concentrated.

The circuit of figure 5 shows two NSI50350A CCRs connected in parallel to maintain constant drive current of up to 700 mA through two high-power white LEDs. In this example, the CCRs are connected to the low side of the LED string. The power dissipated by each CCR is determined by: $(V_{source} - V_{LEDS}) \times I_{REG}$. Using the worst case scenario combining the highest V_{source} , lowest LED V_F , and highest target I_{REG} , an 18 V source driving two white LEDs with a V_F of 3.5 V and 350 mA I_{REG} would require maximum dissipation of:

$$P_D = (18 \text{ V} - (2 \times 3.5 \text{ V})) \times 0.350 \text{ A} = 11 \text{ V} \times 0.35 \text{ A} = 3.85 \text{ W} \text{ for each CCR}$$

If the ambient temperature is to be 85°C , the required dissipation cannot be achieved with standard FR4 PCB. The graph of figure 6 shows how the DPAK devices performs with a thermally enhanced substrate. By combining each DPAK with 900 mm^2 of 2oz copper metal-clad PCB (MCPCB) the requirement to operate up to 3.85 W at an ambient temperature of 85°C will be satisfied.

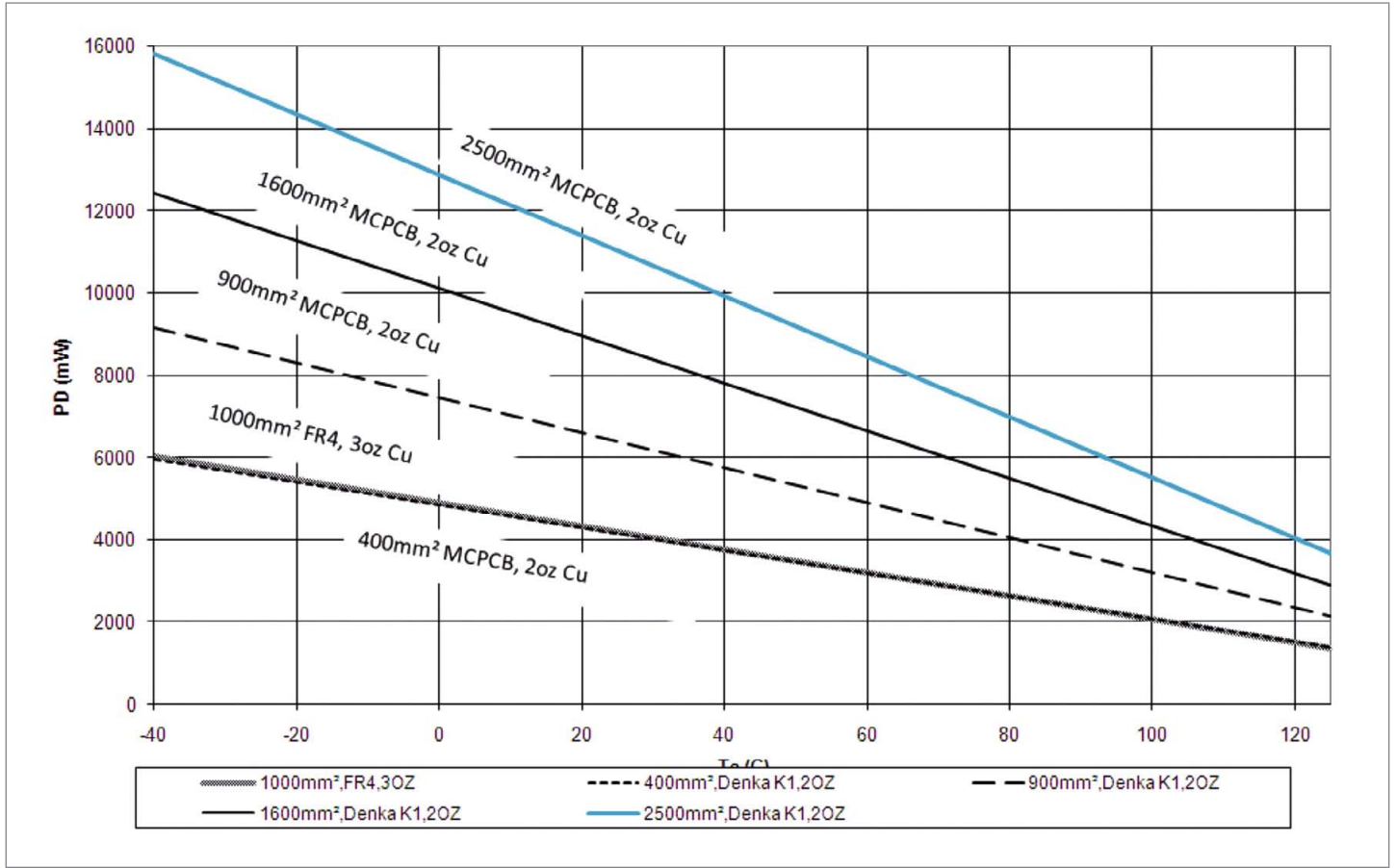

Figure 6: Power dissipation versus ambient temperature for DPAK CCR on thermally enhanced PCB

Conclusion

Constant Current Regulators provide accurate regulation and reduced design complexity in high-power LED applications ranging from signage to automotive lighting. Although they are a popular solution, capable of ensuring

consistent luminosity under varying voltage conditions, the power dissipated in the CCR itself is an important factor in the thermal design of the system. In the same way that designers should ensure adequate PCB thermal performance around the

power LEDs, as recommended by the LED manufacturer, they must also calculate the optimum combination of CCR package and substrate metallisation to prevent the CCR from overheating. ■

LED SYMPOSIUM
professional + EXPO
LpS 2012



LED Lighting Technologies
International Winning Approaches

**25-27 SEPTEMBER 2012
BREGENZ | AUSTRIA**

PROGRAM AVAILABLE
**EARLY BIRD
REGISTRATION
OPEN NOW!**
www.lps2012.com

CONTACT:
LUGER RESEARCH | Moosmahdstrasse 30 | 6850 Dornbirn
T +43 5572 39 44 89 | F +43 5572 39 44 89 90
info@lps2012.com | www.lps2012.com



e.lumix
Technologie AG



OSRAM
Opto Semiconductors



TRIDONIC
enlightening your ideas